



KT09117 2003-04 Toyota 4-Runner 1" Front Coil Spring Spacer Lift Kit

www.DaystarWeb.com
 Tech Support Contact Info
 Tech@DaystarWeb.com
 Phone: 623.907.0081
 Fax: 623.907.0088
 841 South 71st Avenue
 Phoenix, AZ 85043



Bill of materials		
M03532	Coil Spring Spacer	2
S10762	M10-1.25X 50mm Stud	6
S10518	10mm Nylock Nut	6

Do not combine with any other suspension kit.

INSTALLATION INSTRUCTIONS

FRONT

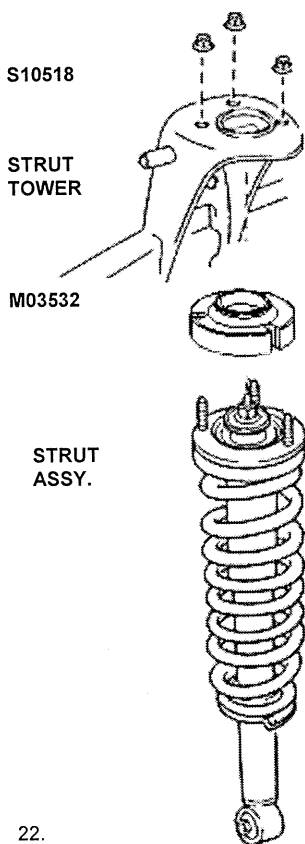

1. Read complete instructions before beginning installation, the following special tools are recommended: Coil spring compressor, floor jack, ball joint separator, jack stands, bench vise, and metric hand tools.
2. Jack the vehicle in the center of the front cross member.
3. Support the vehicle by placing jack stands on the frame cross member so that the front tire... are off the ground.
4. Remove the front tires/wheels.
5. Disconnect the sway bar end links and remove the upper ball joint cotter pin and nut.
6. Separate the upper ball joint from the spindle. (Using ball joint separator or a suitable tool, be careful NOT to damage the ball joint boot)
7. Remove upper strut tower nuts holding strut assembly to strut tower (3) on each side of vehicle.
8. Remove the lower strut bolt from the lower control arm and remove the strut assembly from the vehicle. (Note the direction of the bolt for reinstallation)
9. Compress the coil spring on the strut assembly with a suitable coil spring compressor so that the coil spring has about 3/8" play in the strut and remove the upper strut isolator mount nut.
10. Remove the coil spring isolator from the upper strut mounting plate.
11. Replace the upper strut mounting plate studs with the supplied 10mm longer studs S10762 with a bench vise and a deep well socket. (3 on each side)
12. Reinstall the factory coil spring isolator to the upper strut mounting plate.
13. Reinstall the compressed coil spring onto the strut assembly and re-attach the upper strut mount plate using the stock hardware. See diagram. Torque upper strut mounting plate nut to 18 foot-pounds.
14. Decompress the coil spring in the strut assembly. Make sure that the spring is seated correctly into the strut assembly alignment indentation at the bottom of the strut and the top isolator.
15. Slide the coil spring spacer M03532 onto the top of the strut assembly over the 10mm studs.
16. Install the strut assembly into the strut tower and start the upper three 10mm lock nuts S10518. (Make sure that the bottom of the strut is aligned as well)
17. Install the lower strut bolt in the original position and torque to 100 foot-pounds. (Step 8)
18. Using the floor jack, raise the lower control arm and connect the upper ball joint on the upper control arm to the spindle. Torque nut to 80 ft lbs. and make sure that you replace the cotter pin. (Not supplied)
19. Install the front tires/wheels.
20. Lower the vehicle onto the ground and tighten the upper strut tower 10mm nuts S10518. Torque to 35 foot-pounds. (3 on each side)
21. RETORQUE ALL BOLTS AFTER 500 MILES.

22.

IMPORTANT NOTE: The advertised amount of lift that this kit provides and the thickness of the spacers supplied will not be the same! For example, a 2-1/2" lift may only have 1-1/2" thick spacers. The reason for the difference between the spacer thickness and the amount of lift has to do with suspension geometry. There is a ratio involved, and it is this ratio that determines the thickness of the spacers. Rest assured, installing the spacer supplied will result in the proper amount of lift out at the wheel.

WARNING

This vehicle has been modified to enhance its performance. The steering, braking and handling of this vehicle will differ from standard passenger cars and trucks. This vehicle handles differently from an ordinary vehicle in driving conditions which may occur on streets, highways and off road. Avoid unnecessary abrupt maneuvers, sudden stops, sharp turns and other driving conditions that could cause loss of control, possibly leading to a roll over or other accident that could result in serious injury or death to driver and passengers. If larger tires are installed the speedometer will read lower than the vehicles actual speed. **DRIVE WITH CARE, REDUCE SPEED AND WEAR SEAT BELTS AT ALL TIMES.**

This kit should be installed by a professional mechanic



Instruction sheet P10669 Rev00
 © 2003 Daystar Products International Inc.